

# OST 46T

## ALUMINUM & uPVC

### WEDGE CUTTING MACHINE (Ø600MM SAW)



#### INFORMATION

- Automatic Repetitive cutting machine with extreme accuracy and speed with servo motor motion system for profiles and other mass production profile cutting operations.
- 90° cutting angle
- PLC control system
- Automatic profile slicing feature
- 3 x horizontal and 3 x vertical clamping (pneumatic)
- 3,0 m support right side conveyor with rollers
- Ø600 mm saw
- Possibility to create cutting list
- Protection cover system with safety switch
- Cutting length min./max.: 4 mm/∞
- Saw output height is adjustable
- Hydro-pneumatic cylinder and cooling system

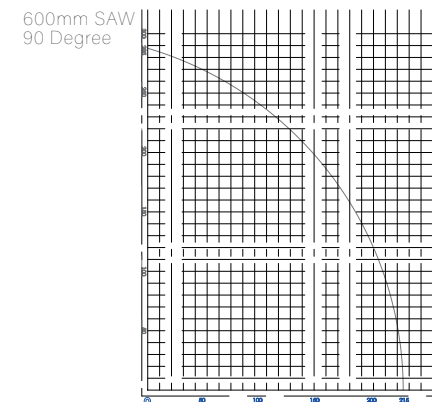
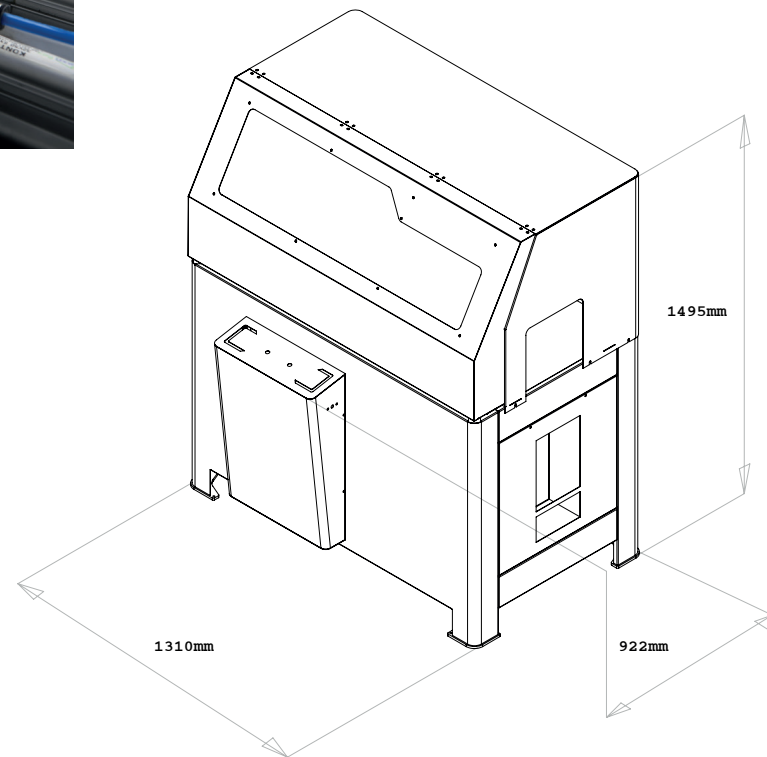

V : 400  
kW : 2.2  
A : 3.3

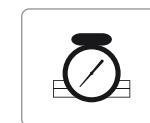

6-8 bar  
4l/lt/syc

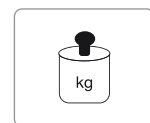

420 kg.

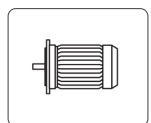

1x2.2 kW  
2810 rpm

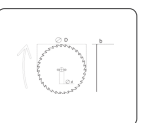

ØD 600 mm  
Ød 32 mm  
b 4,2 x 3,4 mm  
z 120