

OST 40

ALUMINUM & uPVC

UNDERCUT CUTTING MACHINE (Ø450MM SAW)

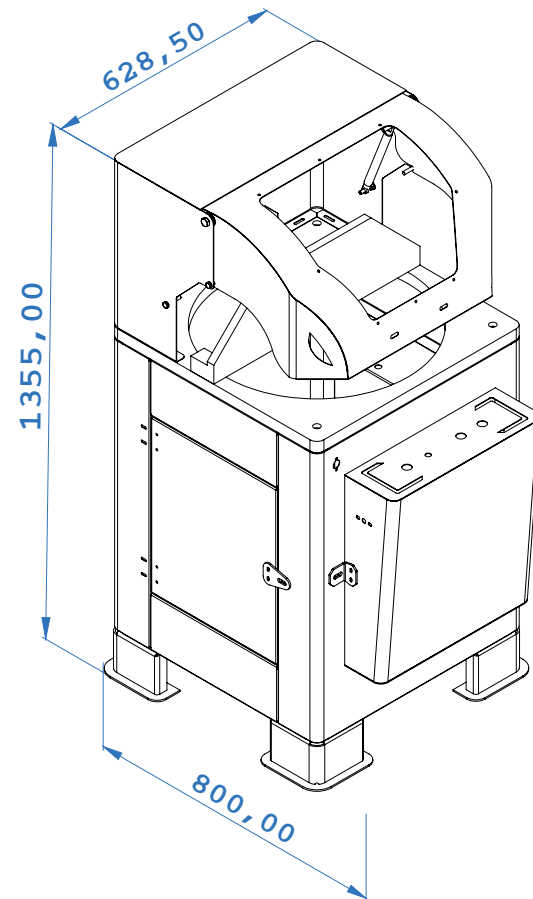
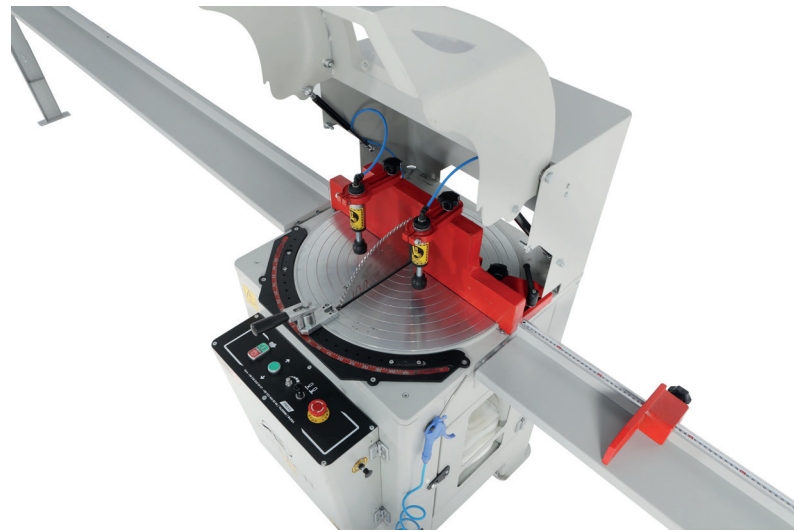
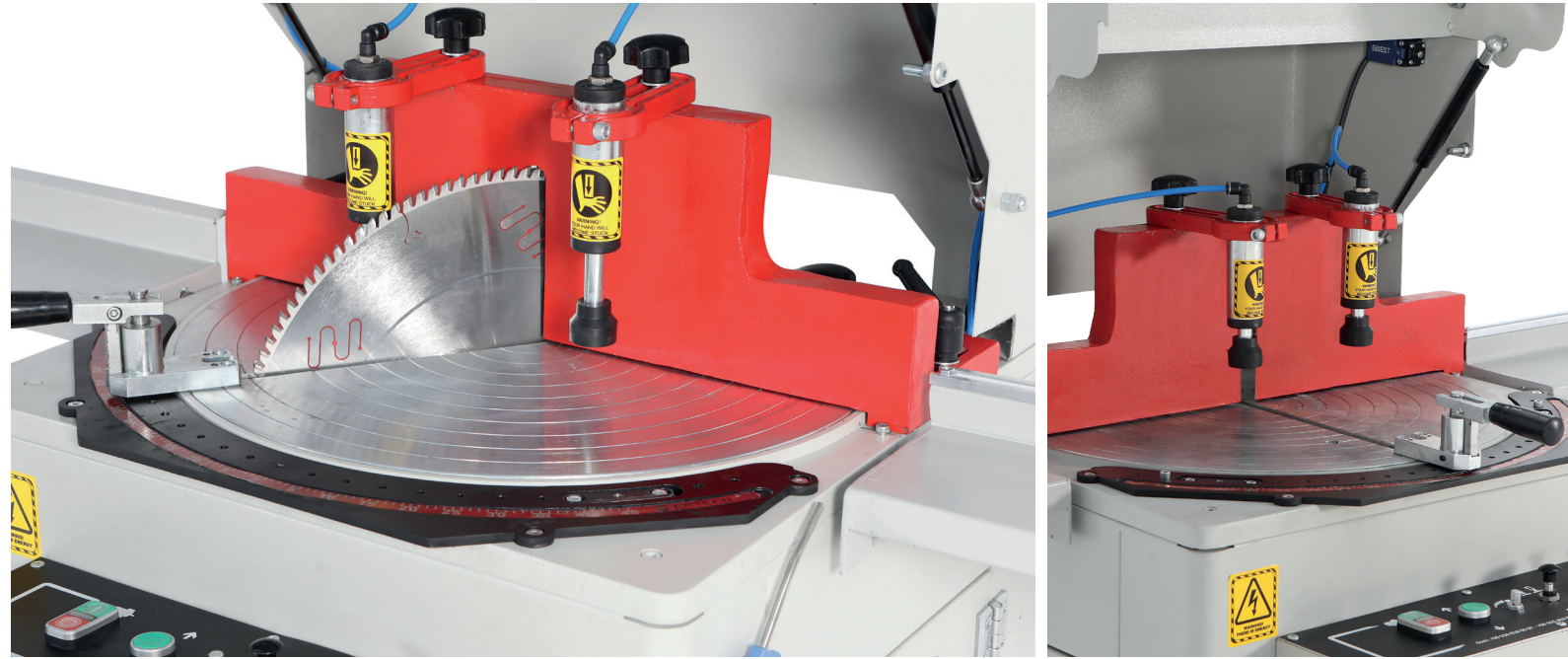

INFORMATION

- Makes precise cuts at 40° – 140° and intermediate degrees.
- Quick adjustment buffers for 15°, 22.5°, 30°, 45°, 60°, 90° degrees
- Table fixing arm for intermediate degrees
- Protection cover for safe cutting
- Diamond saw diameter 450 mm Exit distance: 12.5 cm
- Measuring and transport conveyors are available as standard. (3 meters right-left)

OPTION

- Cooling system for cutting aluminum profiles
- Hydrocheck system for cutting aluminium profiles.

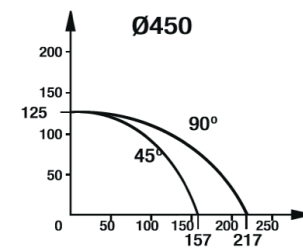

V : 400
kW : 2.2
A : 5

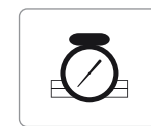

6-8 bar
41/lt/syc

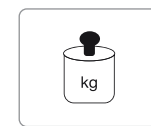

230 kg.

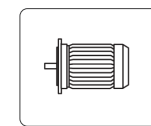

2.2 kW
2810 rpm

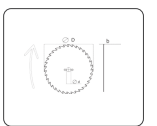

ØD 450 mm
Ød 30 mm
b 4,2 x 3,4 mm
z 120