

OST 20

ALUMINUM & uPVC

AUTOMATIC END MILLING MACHINE

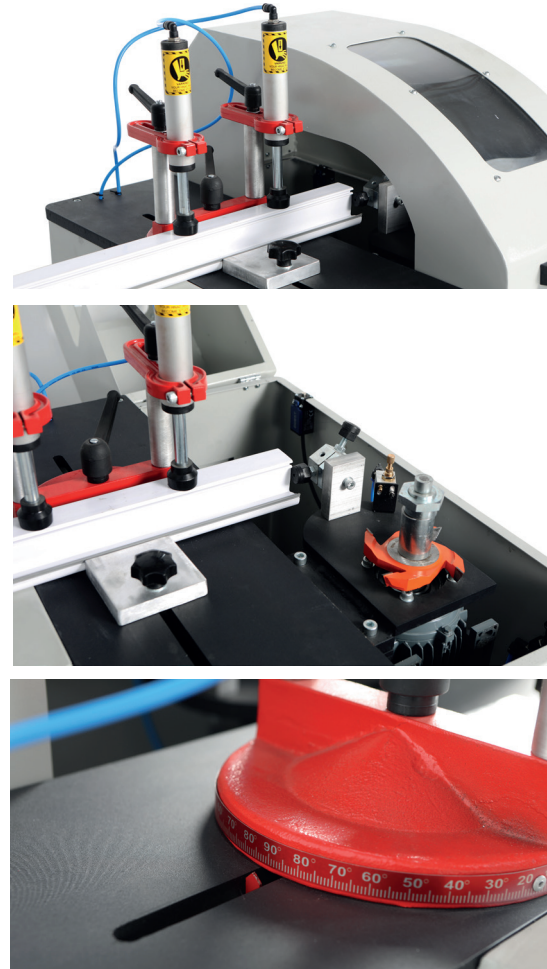

INFORMATION

- Cutting range +45° / -45° and intermediate degrees
- Automatic working cycle -Adjustable cutting speed with regulator on control panel
- Vertical pneumatic clamping kit
- Pneumatic rapid blade change system allows to quickly replace milling cutter groups when making profile system changes
- position rotating star-type stop
- The machine can work with adjustable reference shoulders from -45° to +45° degrees, including all intermediate angles
- Additional fixing of profile by a side stop -Special channel in stop plate is made for the best fixing of profile
- Strengthen engine bearing axle
- Special storage section for milling cutter holders
- Profile supporting arm -2 items of cutter holders

OPTION
-Hydropneumatic and cooling systems for aluminium profile cutting

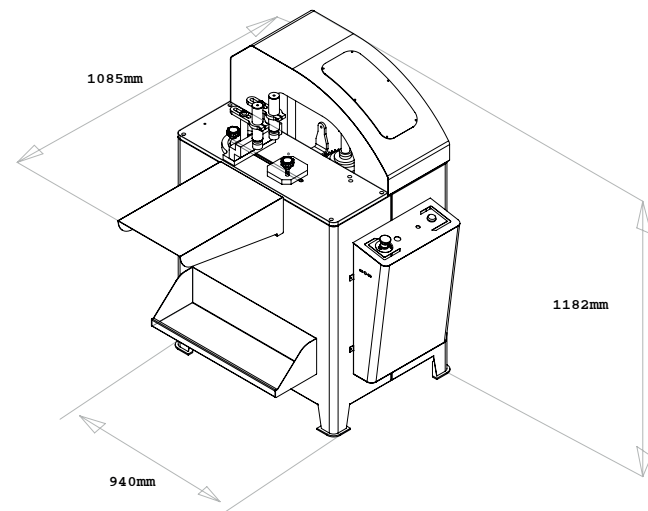

V : 400 kW : 1.1	6-8 bar 3/lt/syc	100 kg.	1.1 kW 2810 rpm	B max = 160 mm A (mm) = 30 mm n = 2810