

# OST 46

## ALUMINUM & uPVC

UNDERCUT CUTTING MACHINE (Ø600MM SAW)

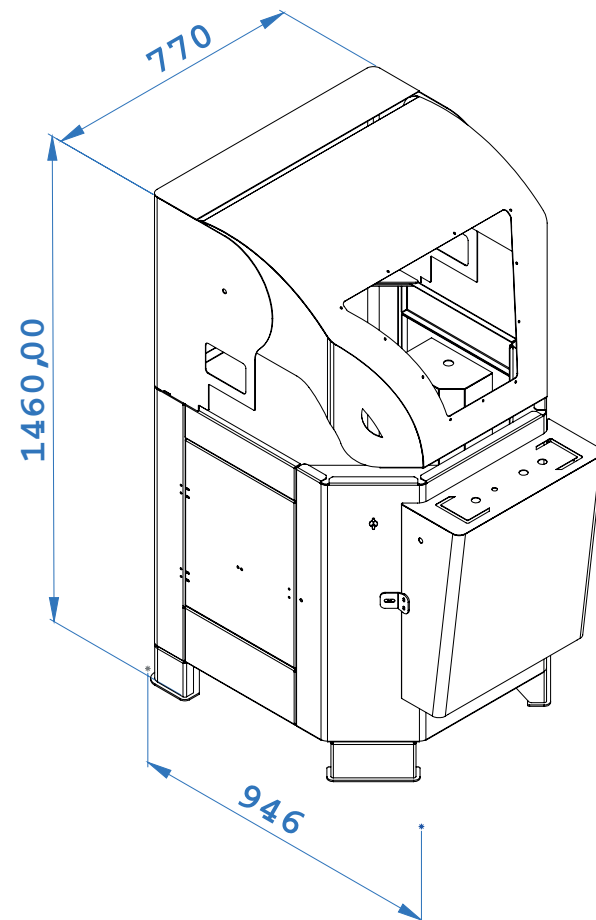
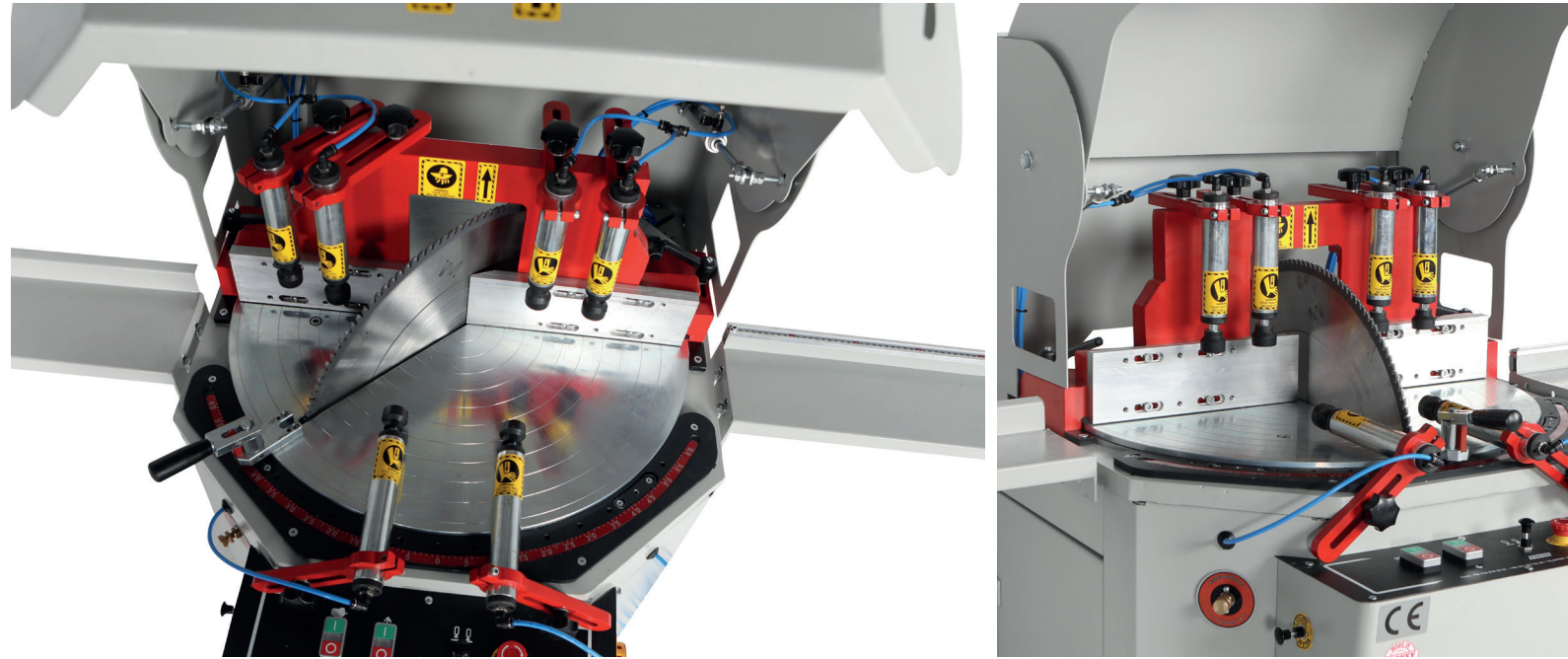

### INFORMATION

- It is used for cutting aluminum and UPVC profiles.
- Hydro-Pneumatic cutting process,
- It can cut at fixed angles of -60°, -45°, -30°, -22.5°, -15°, 0°, +15°, +22.5°, +30°, +45°, +60° to the right and left.
- Pneumatic, vertical and horizontal press
- Ø600 Diamond Tipped Aluminum Saw Blade.
- Roller Conveyor Available. (Right-Left 3m)
- Oil Spray System.
- It can make precise cutting thanks to its 2.2KW motor and hydrocheck.

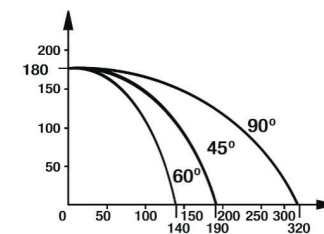

V : 400  
kW : 2.2  
A : 3.3

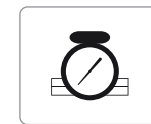

6-8 bar  
41/lt/syc

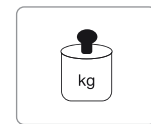

420 kg.

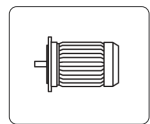

2.2 kW  
2810 rpm

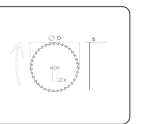

ØD 600 mm  
Ød 30 mm  
b 4,2 x 3,4 mm  
z 120