

OST 30

uPVC GLAZING BEAD

AUTOMATIC CUTTING MACHINE

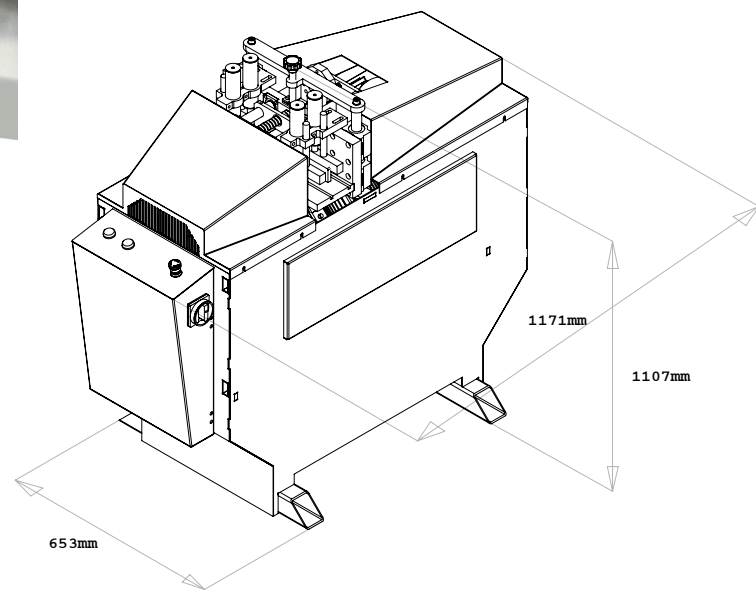
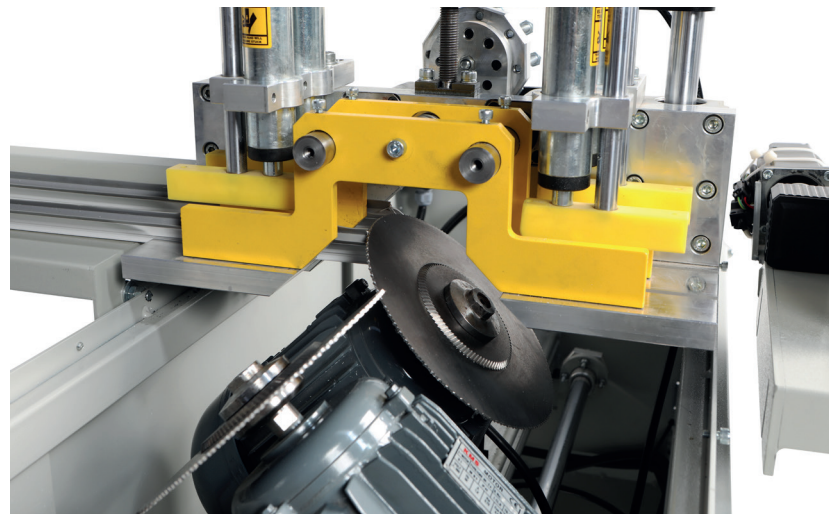

INFORMATION

- 45 Degree Cutting Process of Lath Profiles
- 2 Sawed
- 10 Different Moulding Cutting Features
- Ability to cut 2 laths at the same time
- Right / Left Conveyor System for Long Slats 3 MT X 2
- Lath Claw Adjustment Mechanism
- Pneumatic Compression System
- Ability to cut aluminum slats by attaching a diamond-tipped saw upon request (with cooling system)
- Adjustable cutting speed



V : 400
kW : 1,2

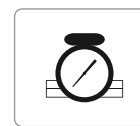

6-8 bar
25/lt/syc

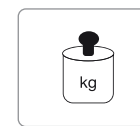

150 kg.

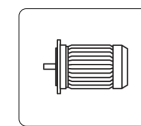

2x0,55 kW
2810 rpm

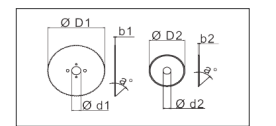

ØD1 = 200mm ØD2 = 100mm
Ød1 = 32mm Ød2 = 25mm
b1 = 1,8mm Øb2 = 3mm
z1 = 160 Z = 80
α = 45° α = 45°